

MISSION™ OS

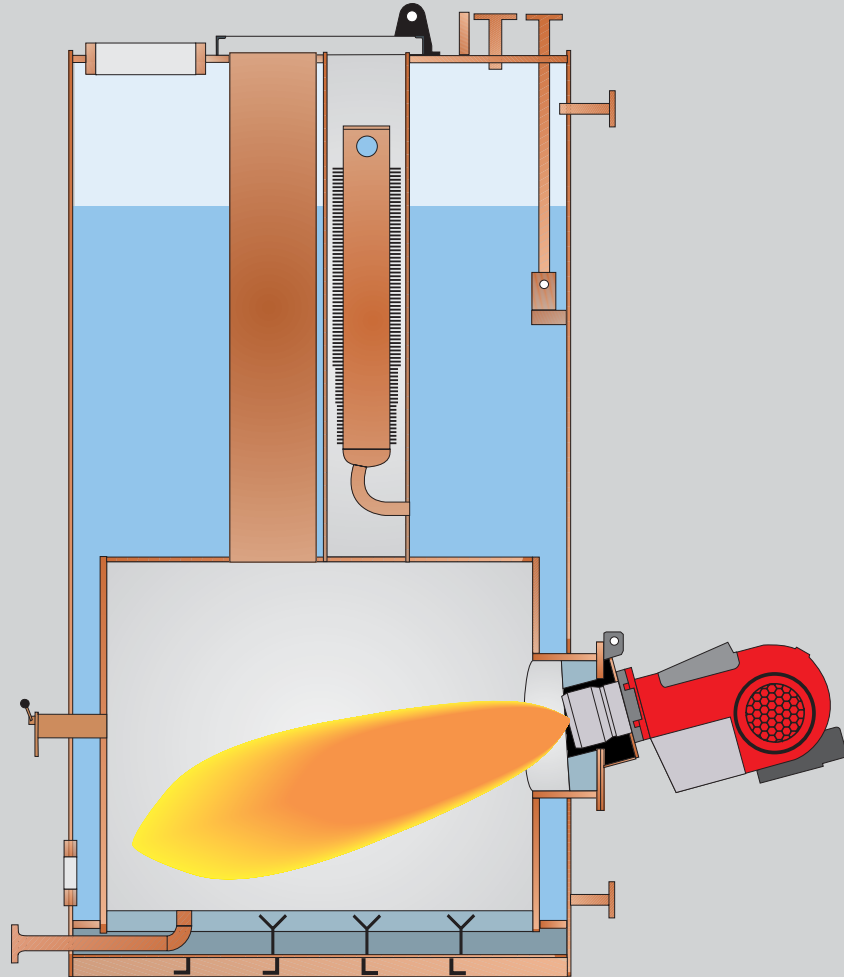

The MISSION™ OS is supplied as a standard, preassembled boiler unit. High performance is ensured by the use of the optimally designed pin-tube elements. These elements are also used for support of the top plates of the furnace and boiler. The inclined mounting of the burner provides good combustion with all grades.

Capacity range: 1,600–6,500 kg/h

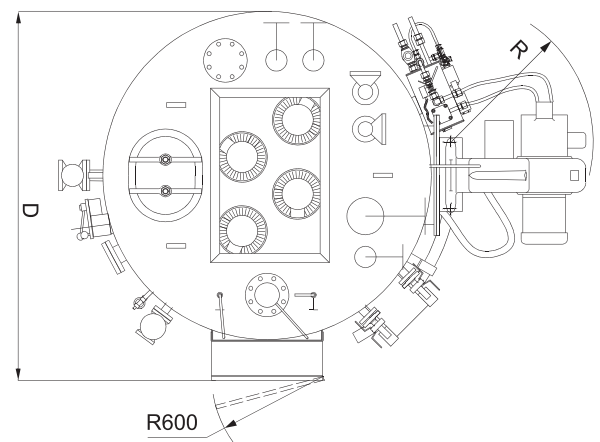
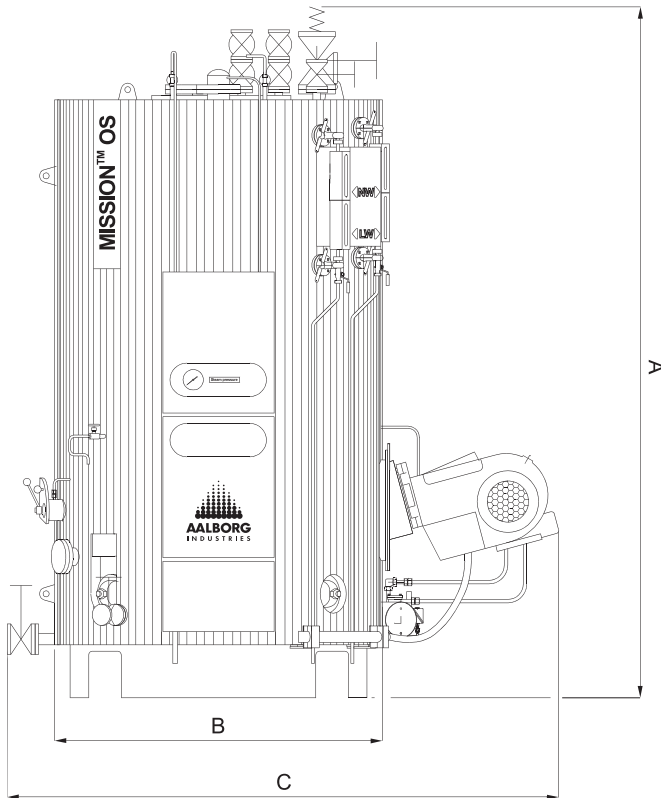

STANDARD PRODUCT RANGE

Capacity and dimensions

Steam capacity	Design pressure	Outside dimensions (incl. insulation)					Boiler dry weight	Boiler operation weight
		A	B	C	D	R		
kg/h	bar (g)	mm	mm	mm	mm	mm	ton	ton
1,600	10	3,725 (4,530)	1,770	2,980	1,990	760	4.5 (5.1)	7.0 (9.0)
2,300	10	3,925 (4,625)	1,970	3,185	2,190	760	6.2 (6.9)	9.2 (11.4)
2,500	10	3,925 (4,740)	1,970	3,360	2,190	1,075	6.2 (7.0)	9.2 (11.7)
3,300	10	4,510 (5,120)	2,170	3,585	2,580	1,075	8.3 (9.0)	12.3 (14.6)
4,000	10	4,510 (5,345)	2,170	3,530	2,580	1,075	8.3 (9.3)	12.3 (15.4)
5,400	10	5,170 (5,910)	2,470	3,850	2,880	1,075	11.3 (12.5)	17.2 (20.7)
6,500	10	5,170 (6,135)	2,470	4,100	2,880	1,260	11.3 (12.8)	17.2 (21.8)

The dimensions are valid for DNV, LRS (GL, SeeBG)